

4

3

2

1

SERVICE ACCESS DOOR

FRONT

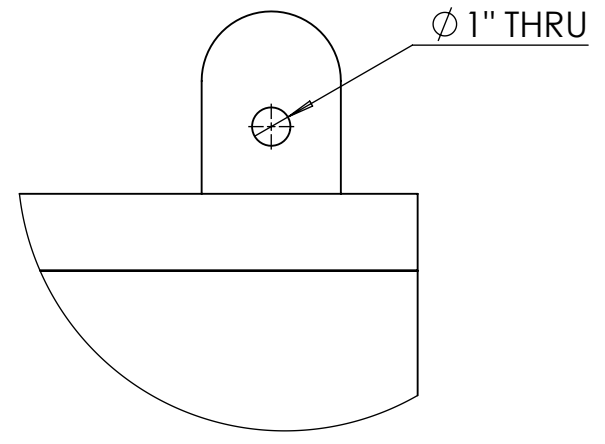
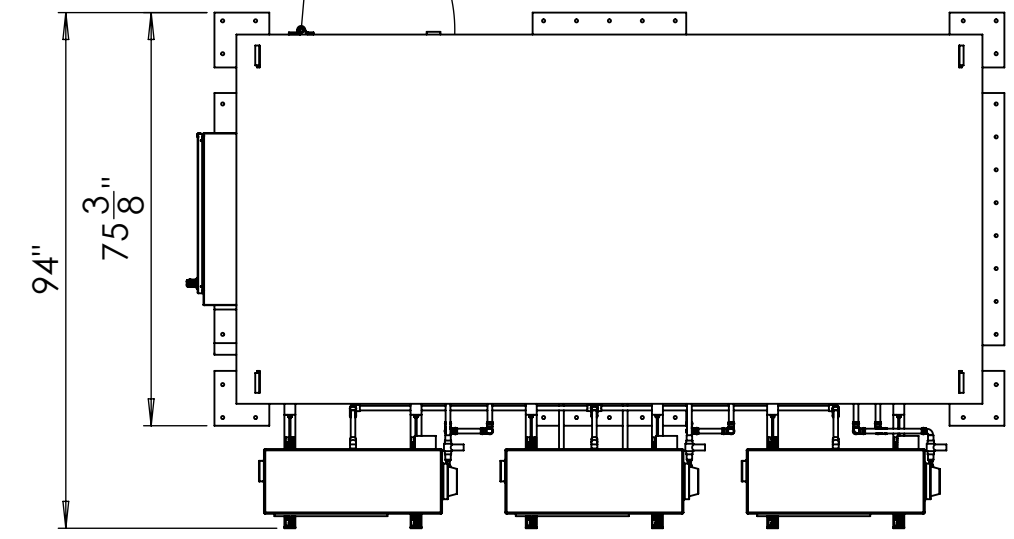

DETAIL A
RIGGING EYELET (X4)
SCALE 1 : 5

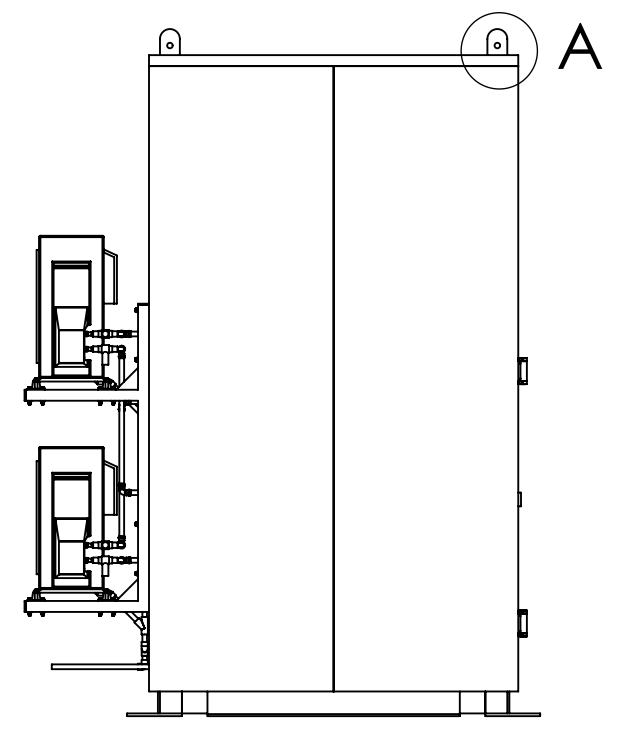
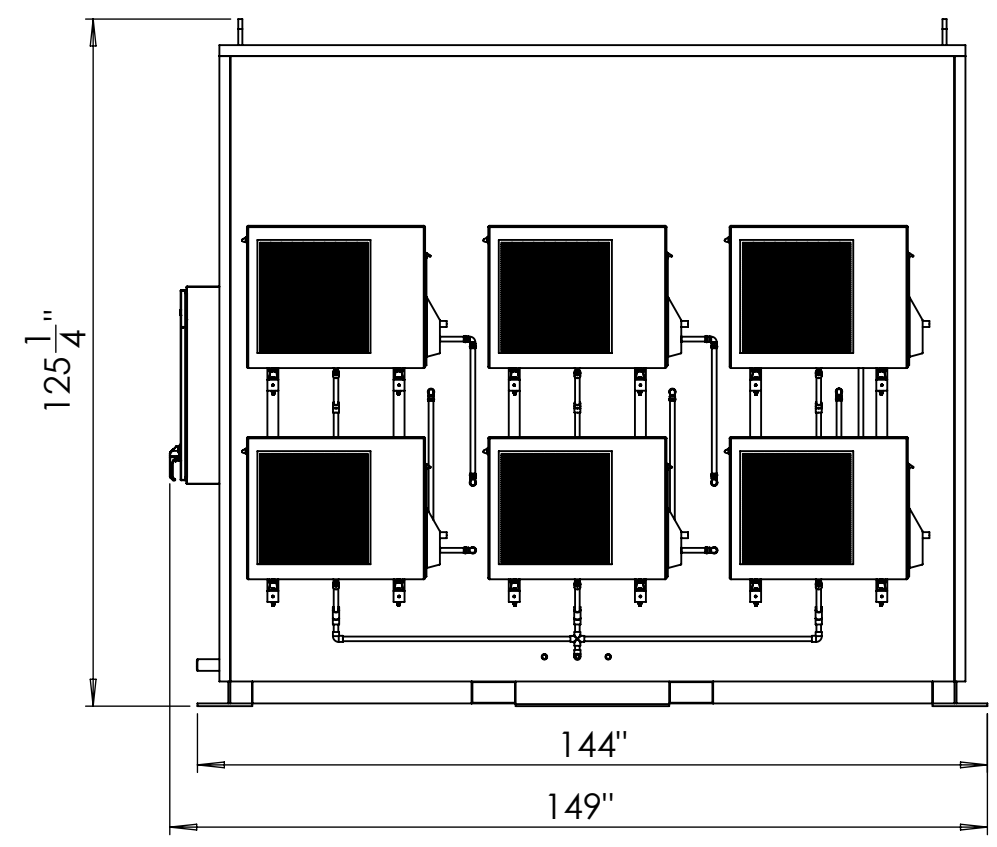

NOTES:

REQUIRED SERVICE CLEARANCES:
36" MIN. BEYOND SIDES
72" MIN. BEYOND FRONT & REAR

ALL DIMENSIONS IN INCHES
UNLESS OTHERWISE NOTED

SMALL PLANET SUPPLY
TUMWATER, WA

TITLE:
WD1T-90-0500-119-12
SUBMITTAL

SIZE	DWG. NO.	REV
B	003-00003	A

SCALE: 1:35

SHEET 1 OF 6

4

3

2

1

B

B

A

A

4

3

2

1

B

B

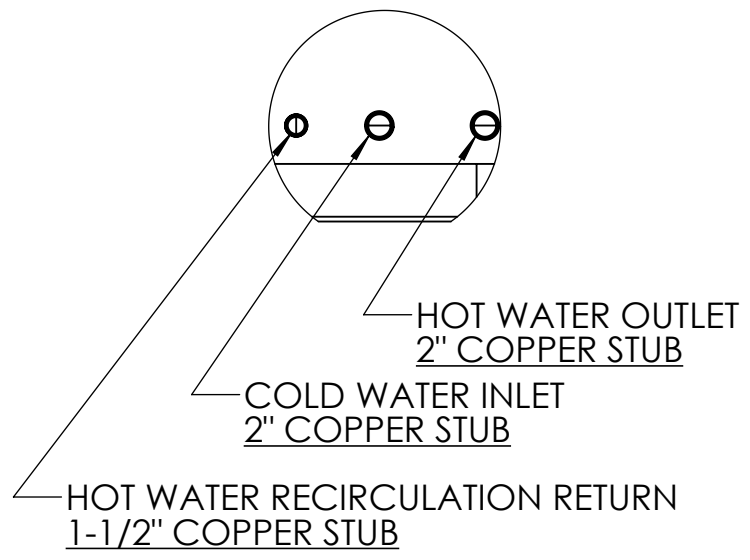
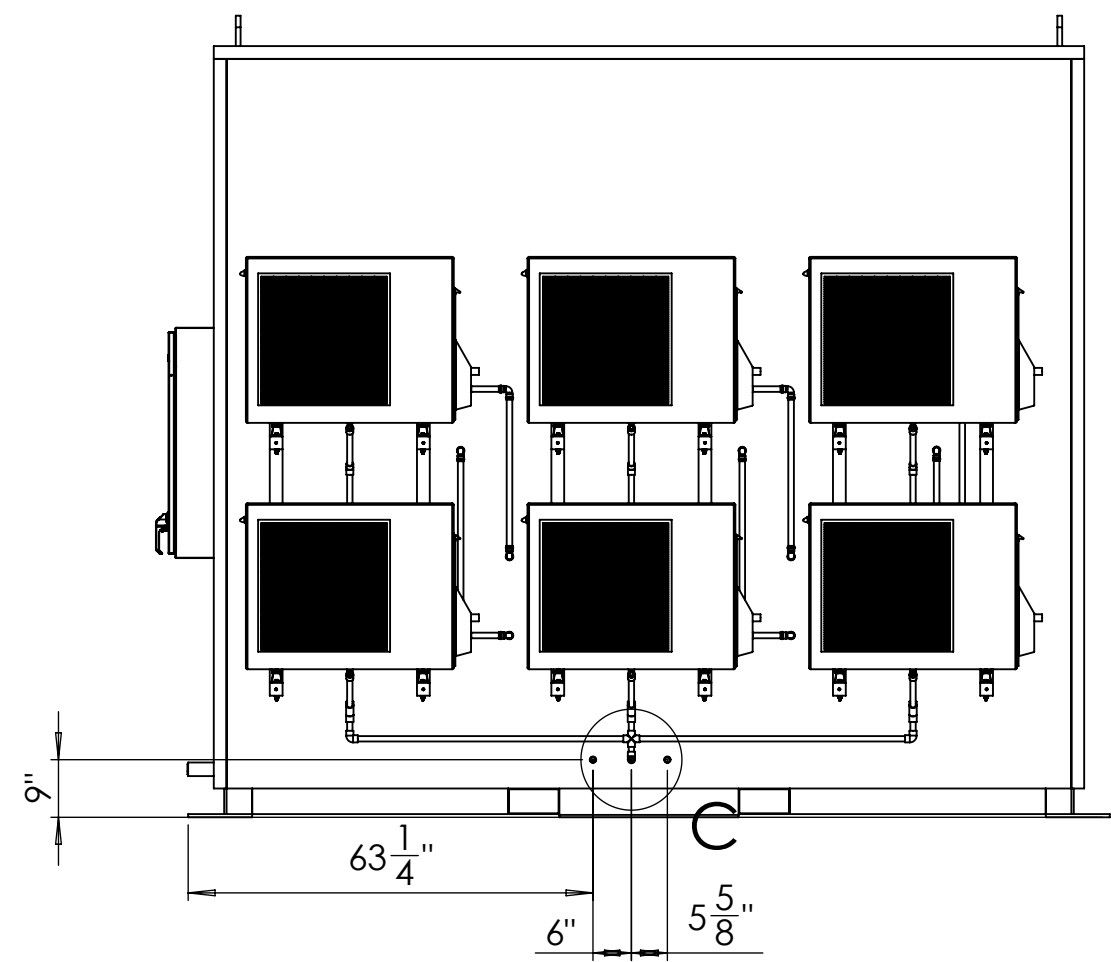
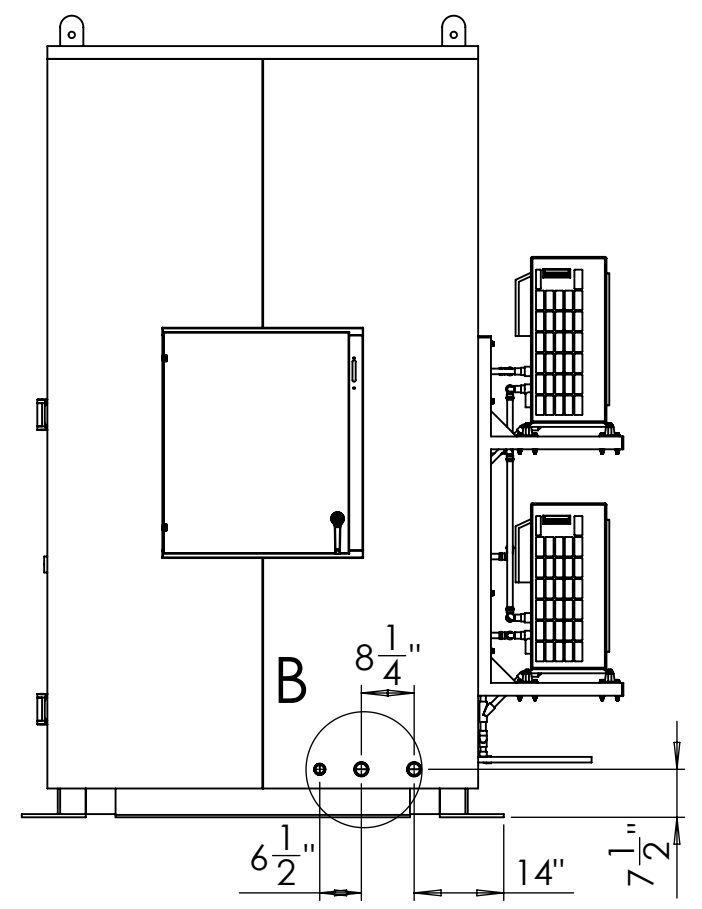

DETAIL B

BUILDING WATER CONNECTIONS

SCALE 1 : 15

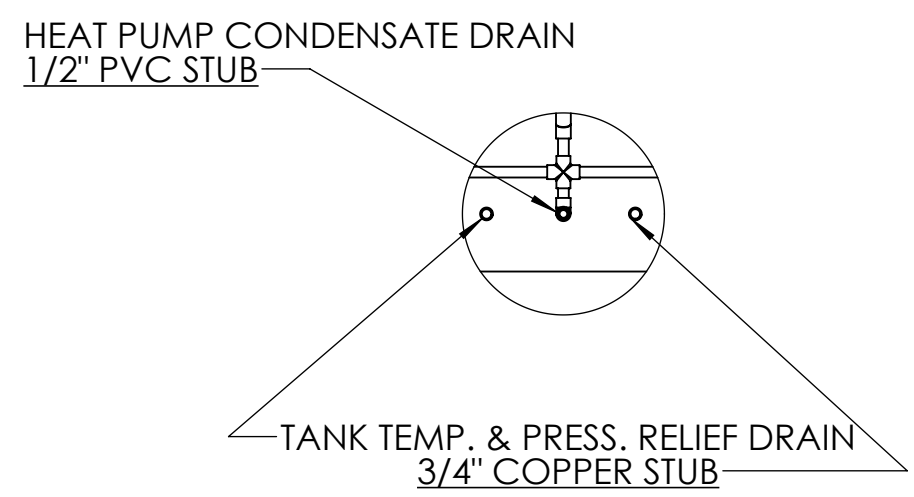

DETAIL C

DRAIN CONNECTIONS

SCALE 1 : 15

NOTES:
ALL DIMENSIONS IN INCHES
UNLESS OTHERWISE NOTED

SMALL PLANET SUPPLY
TUMWATER, WA
TITLE:
WD1T-90-0500-119-12
SUBMITTAL

SIZE	DWG. NO.	REV
B	003-00003	A
SCALE: 1:30		SHEET 2 OF 6

4

3

2

1

A

A

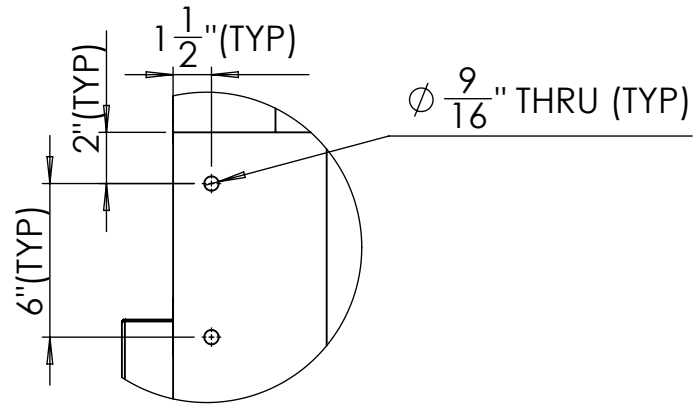

DETAIL D
SCALE 2 : 15

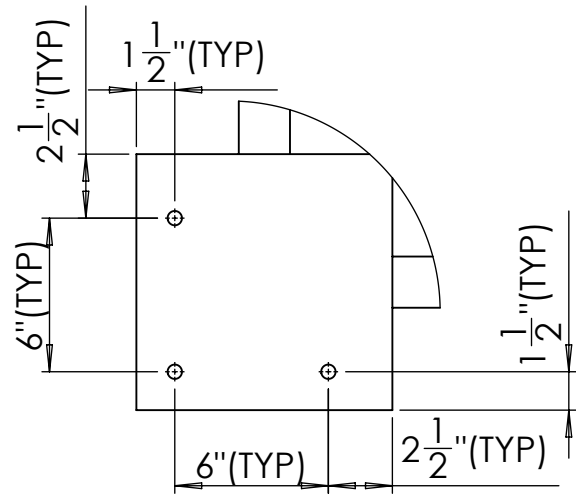

DETAIL E
SCALE 2 : 15

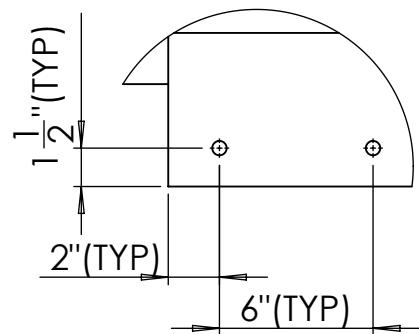

DETAIL F
SCALE 2 : 15

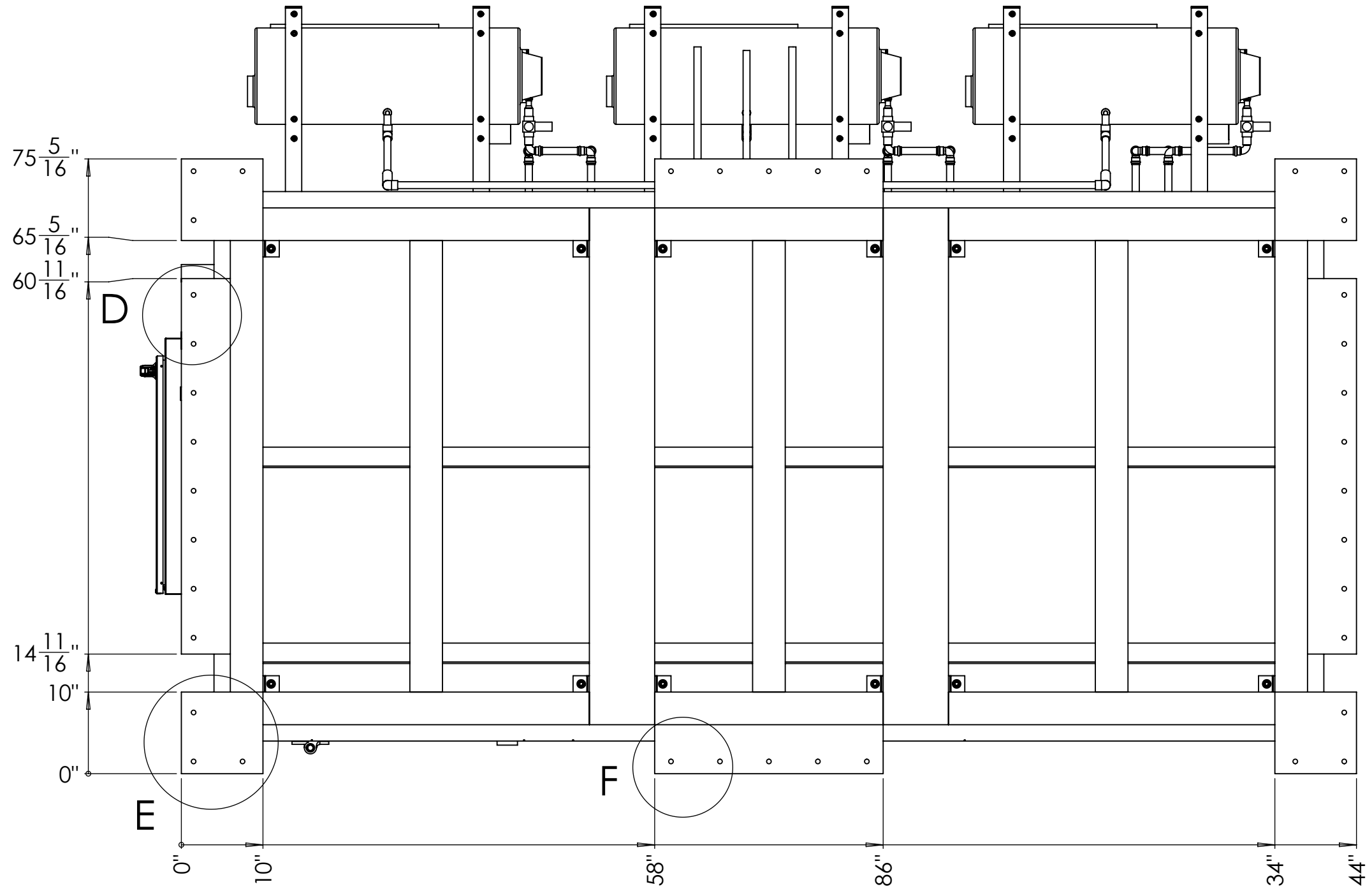

SIDE MOUNT ANCHOR BOLTS TO BE SPECIFIED BY LICENSED PROFESSIONAL ENGINEER TO WITHSTAND (PER ANCHOR):

- CONCRETE AND MASONRY:
 - a. IF 2,500# PULLOUT LOAD AND 1,250# SHEAR LOAD ANCHORS INSTALLED THROUGH CORNER BASE PLATES, NO ANCHORS REQUIRED.
 - b. 500# PULLOUT LOAD AND 250# SHEAR LOAD OTHERWISE
- WOOD FRAMING:
 - a. 250# PULLOUT LOAD AND 125# SHEAR LOAD

CORNER ANCHOR BOLTS TO BE SPECIFIED BY LICENSED PROFESSIONAL ENGINEER TO WITHSTAND (PER ANCHOR)

- CONCRETE AND MASONRY:
 - a. 2,500# PULLOUT LOAD AND 1,250# SHEAR LOAD ANCHORS INSTALLED THROUGH SIDE MOUNTS
 - b. 500# PULLOUT LOAD AND 250# SHEAR LOAD OTHERWISE
- WOOD FRAMING:
 - a. 250# PULLOUT LOAD AND 125# SHEAR LOAD

NOTES:
ALL DIMENSIONS IN INCHES
UNLESS OTHERWISE NOTED

SMALL PLANET SUPPLY
TUMWATER, WA
TITLE:
WD1T-90-0500-119-12
SUBMITTAL

SIZE B	DWG. NO. 003-00003	REV A
SCALE: 1:15		SHEET 3 OF 6

4

3

2

1

PERFORMANCE

TOTAL HEAT PUMP CAPACITY [MBH]	92.4
TOTAL PRIMARY STORAGE VOLUME (GAL.)	500
MAX. DAILY HW OUTPUT (GAL. / DAY)*	1,920
MAX. DAILY RUNTIME (hr. / DAY)	16
NOMINAL HOURLY HOT WATER OUTPUT (GAL. / hr.)	120
RECIRCULATION PUMP OUTPUT (W)	5-45
RECIRC. PUMP MAX. HEAD (FT. - H ₂ O)	18
NOMINAL OPERATING SOUND PRESSURE LEVEL (dBA)	40
MAX. SYSTEM WATER PRESSURE (PSI)	94

*100°F LIFT AND 16 hr./DAY MAX. COMPRESSOR RUNTIME

COMPONENTS

(6) HEAT PUMP WATER HEATERS	REFRIGERANT TYPE: R-744 (CO ₂)
	TOTAL CHARGE: 152 OZ.
	AIRFLOW (CFM): 3,600
	EXTERNAL STATIC PRESSURE (IN.-H ₂ O): 0
(1) 500 GAL. STORAGE TANK	
(1) SWING TANK, 119 GAL. / 12 kW	
(1) EXPANSION TANK, 45 GAL. / 30 GAL. ACCEPTANCE	
(1) ELECTRONIC MIXING VALVE	1 IN. BODY: 3-94 GPM RECOMMENDED FLOW RANGE
(1) RECIRCULATION PUMP, ECM	
(1) HEAT PUMP STAGING CONTROLLER	
(1) INCOMING COLD WATER WYE-STRAINER, 20-MESH	

CONSTRUCTION

ENCLOSURE PANELS	R8 INSULATION POWDER COAT FINISH
PIPING	TYPE K COPPER DIELECTRIC CONNECTIONS WHERE REQUIRED
	1-1/2" INSULATION, MIN. R-VALUE: 8.6
UL508A - LISTED ELECTRICAL PANELS	POWER DISTRIBUTION EQUIPMENT / STAGING CONTROLLER
PAINTED CARBON STEEL FRAME	
ELECTRICAL DISTRIBUTION PANEL WITH MAIN DISCONNECT	
INDIVIDUAL COMPONENT DISCONNECTS ON HEAT PUMPS AND SWING TANK	
HEAT PUMPS MOUNTED WITH VIBRATION ISOLATORS	
INSULATED BASE NOT PROVIDED BELOW STORAGE AND SWING TANKS	
REVERSE-RETURN HEAT PUMP MANIFOLD PIPING CONFIGURATION	
INDIVIDUAL HEAT PUMP ISOLATION, DRAIN AND CHECK VALVE	

ELECTRICAL

SUPPLY	208V/3Ph/60Hz
TOTAL CONNECTED LOAD [kVA]	27.6
FULL LOAD AMPS [A]	76.6
MINIMUM CIRCUIT AMPACITY [A]	98.5
MAXIMUM OVERCURRENT PROTECTION [A]	100

WEIGHT (APPROX.)

DRY (LBS.)	5,900
WETTED (LBS.)	11,000

NOTES:

ALL DIMENSIONS IN INCHES
UNLESS OTHERWISE NOTEDSMALL PLANET SUPPLY
TUMWATER, WA

TITLE:

WD1T-90-0500-119-12
SUBMITTAL

SIZE DWG. NO.

B 003-00003

REV

A

SCALE: 1:30

SHEET 4 OF 6

4

3

2

1

B

B

A

A

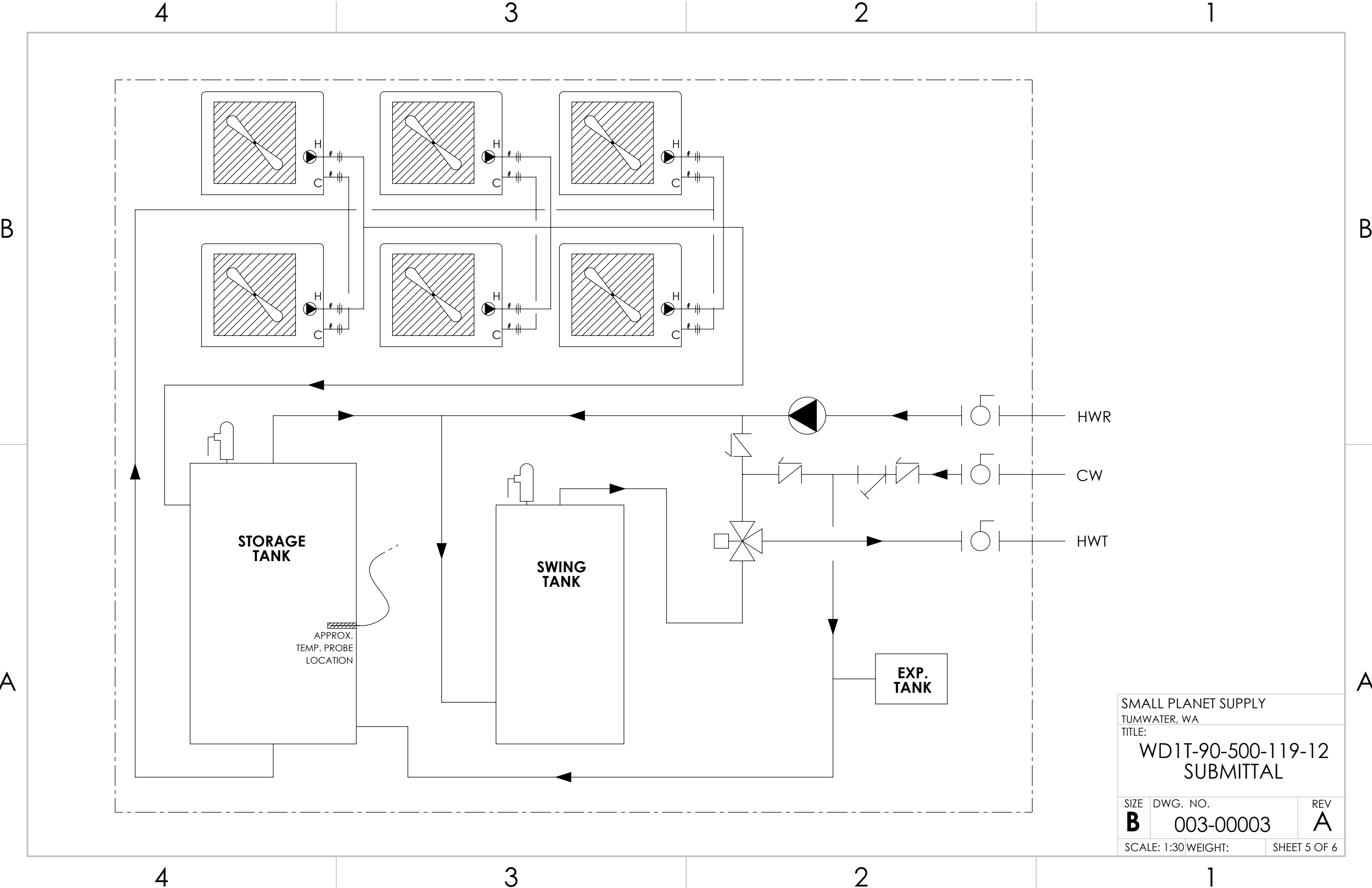

SMALL PLANET SUPPLY
TUMWATER, WA

TITLE:
WD1T-90-500-119-12
SUBMITTAL

SIZE	DWG. NO.	REV
B	003-00003	A

SCALE: 1:30 WEIGHT: SHEET 5 OF 6

4

3

2

1

B

B

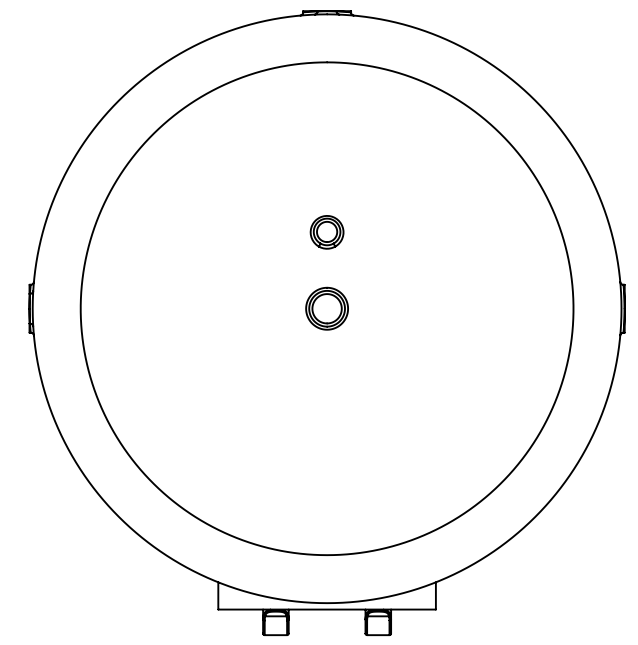
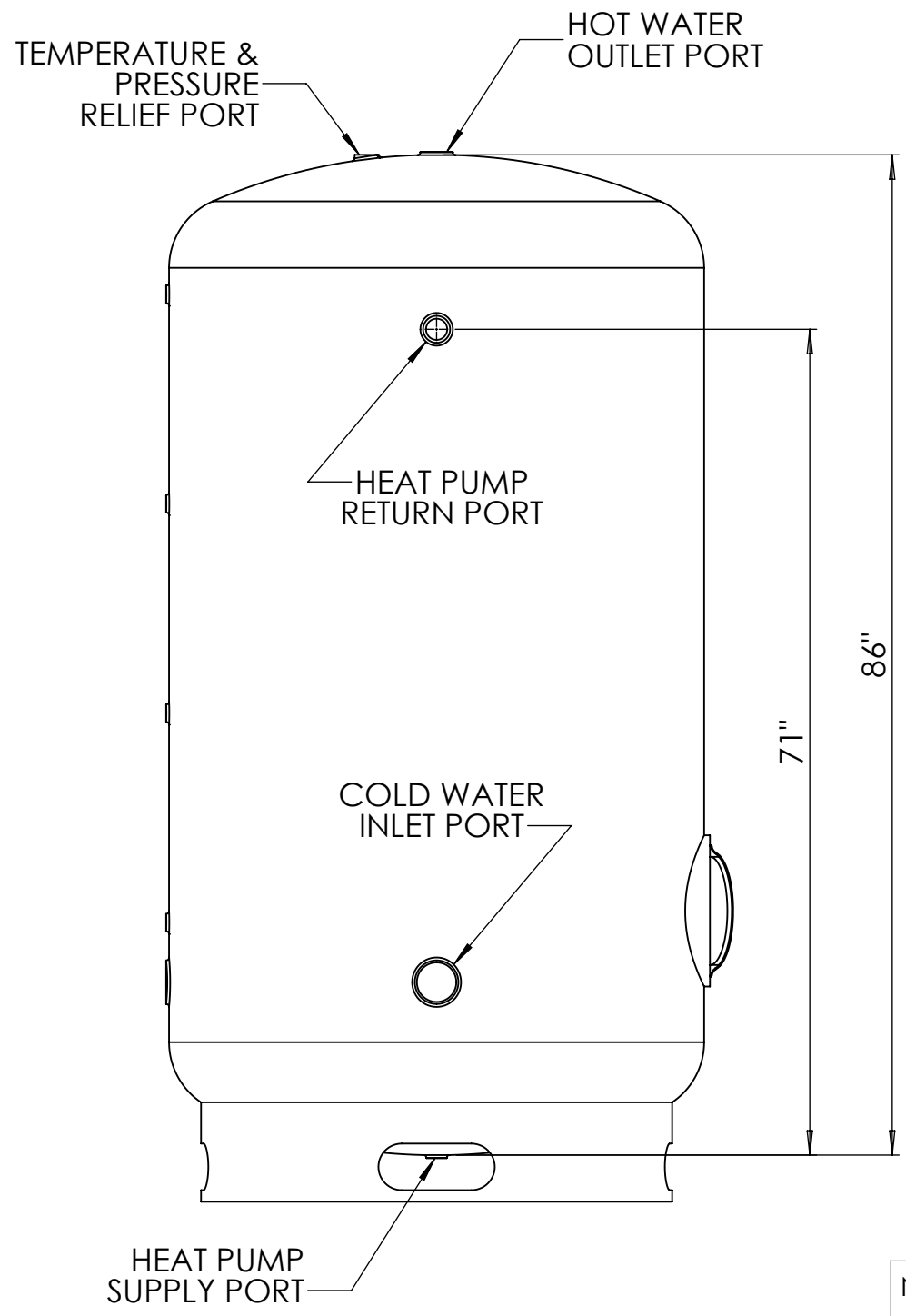
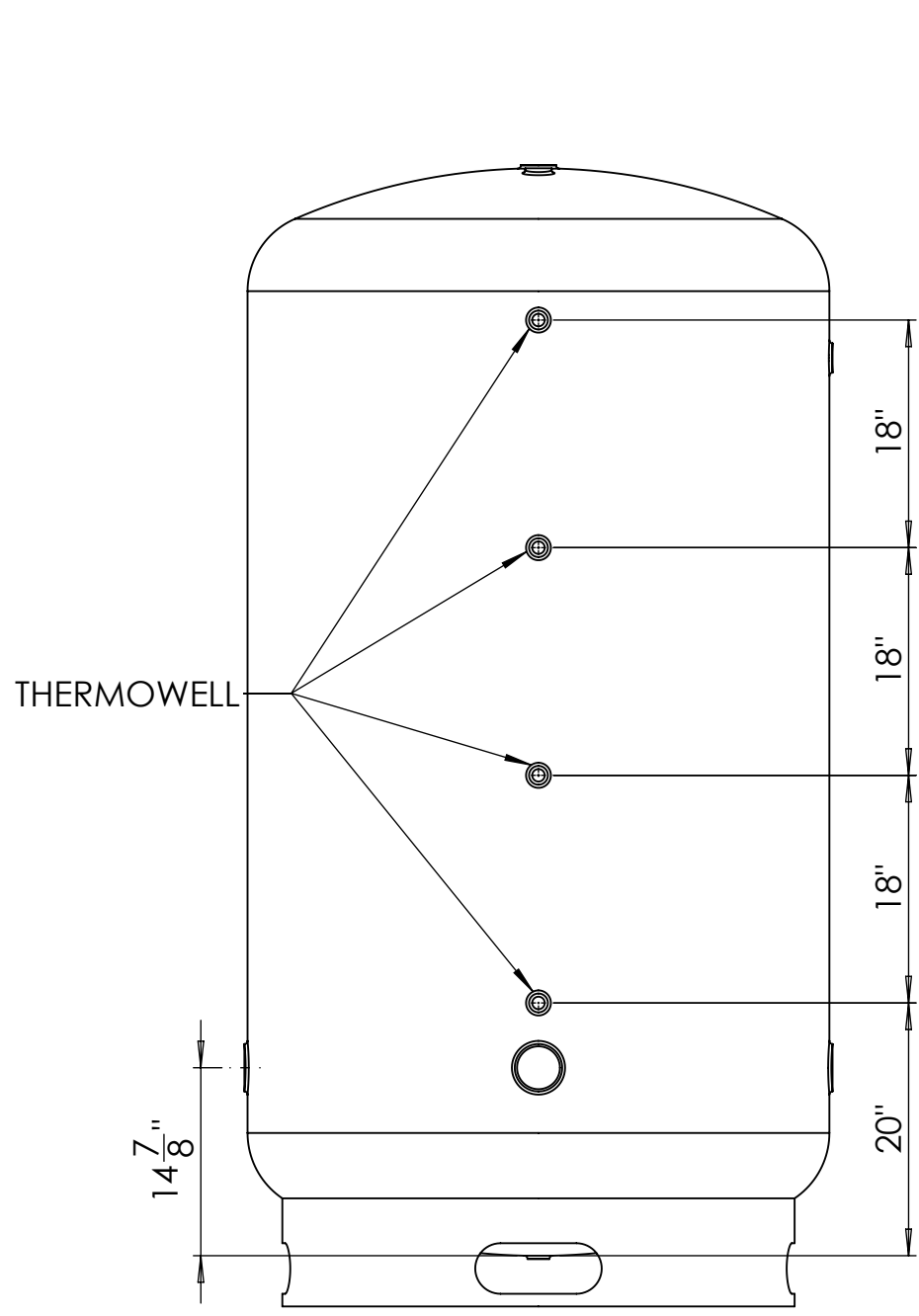

A

A

4

3

2

1

NOTES:		SMALL PLANET SUPPLY	
ALL DIMENSIONS IN INCHES		TUMWATER, WA	
INSULATION R12.5 MIN.		TITLE:	
VOLUME: 500 GAL. (US)		WD1T-90-500-119-12	
		SUBMITTAL	
SIZE	DWG. NO.	REV	
B	003-00003	A	
SCALE: 1:15		WEIGHT:	SHEET 6 OF 6